

**GOLD NOTE**  
il suono italiano

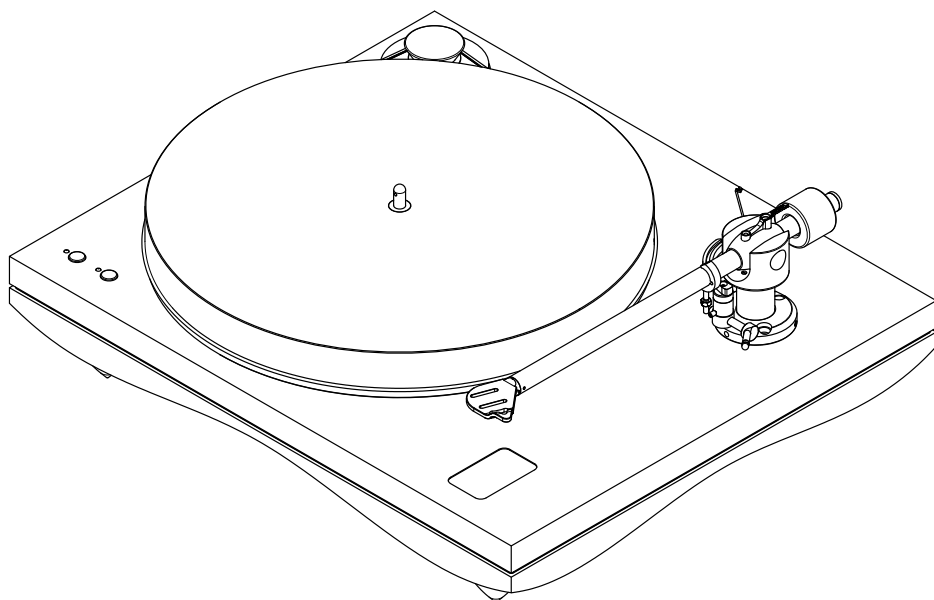

# PIANOSA

THE ITALIAN TURNTABLE

USER MANUAL



# INDEX

PACKAGE CONTENT.....	P. 3
INTRODUCTION.....	P. 4
KEY FEATURES.....	P. 5
TECHNICAL SPECIFICATIONS.....	P. 6
SET-UP INSTRUCTIONS.....	P. 7
INSTALLING THE PLATTER.....	P. 8
INSTALLING THE BELT AND THE TONEARM CABLE.....	P. 10
ANTI-SKATING, AZIMUTH, COUNTERWEIGHT ADJUSTMENTS.....	P. 11
VTA SETUP.....	P. 12
POWER SUPPLY.....	P. 13
POWER ADAPTER AND SPEED CONTROL.....	P. 14
CALIBRATION: CARTRIDGE OVERHANG, ALIGNMENT AND SPEED.....	P. 15
CARTRIDGE ALIGNMENT.....	P. 16
DETACHABLE DUST COVER.....	P. 17
WARRANTY AND SERVICE.....	P. 18
TROUBLESHOOTING.....	P. 19
IMPORTANT SAFETY INFORMATION.....	P. 20

# PACKAGE CONTENT

- 1 Turntable Pianosa
- 1 Dust Cover (detachable)
- 1 Power adapter with 12V cable
- 1 B-5.1 tonearm with the cable already installed
- 1 Counterweight
- 1 Drive Belt
- 1 Turntable Clamp
- 1 Platter Spindle tip to clamp the platter
- 3 Spike Washers
- 1 Oil Vessel
- 1 Allen Key 2,5mm to block the arm lift board
- 1 Allen Key 2,0mm to remove the din pillar
- 1 Allen Key 1,5mm
  - To Adjust the VTA of the tonearm,
  - To Remove the lift Cueing
  - To Adjust the anti skate cylinder
- 1 Allen Key 0,9mm to Adjust the Tonearm Shell Azimuth
- 1 Protractor/Overhang for Cartridge Alignment with Stroboscope
  - for Fine Speed Adjustments
- 1 Gn Stylus Gauge
- 1 Felt Matt
- 1 User Manual

# INTRODUCTION

The Pianosa follows the beauty and technical innovation of the new generation of turntable designed by Gold Note featuring unique musical qualities and the legacy of strong Tuscan origins.

The Pianosa features a 50mm curved plinth made of lacquered MDF or Harwood Walnut, quality materials chosen for their exceptional elasticity, strength and high density, being at the same time evocative of Tuscany landscape, one of the most recognisable places in the world, creating a strong union between the finished product and the skilful local craftsmen who made it by hand.

The curved plinth is precisely cut in the inner side to find the perfect tuning of the wood that is interfaced with a 3mm stainless steel board. The structure is completed with a 20mm thick black lacquered MDF top plinth, where the electronic board of the turntable is installed, thus lowering the frequency resonance.

The curved wooden plinth is the result of years of research at the Gold Note engineering labs in order to replace a bigger mass plinth of a more traditional rectangular shape structure; the extra rigidity given by the curves of the plinth allow a sophisticated technical design and a great exclusive look.

Thanks to our proprietary power control generator based on a Quadral-Core micro-controller, Pianosa can effectively control vibrations and deliver high torque for the greatest dynamic and resolution.

The Pianosa features the same 12Volt synchronous motor developed for Mediterraneo.

The Power Supply electronically controls the 33 $\frac{1}{3}$ rpm, the 45rpm modes and the fine speed adjustment storing the selection permanently in memory even when disconnected from the power.

The new perfectly polished hourglass motor pulley also allows the turntable belt to spin smoothly thus reducing the wow&flutter and noise as never before.

The 60mm long platter Spindle/bearing comes directly from the top quality design of the Mediterraneo; it is fully recessed into the Black Lacquered MDF top plinth in order to keep the thick platter as closest as possible to the turntable structure to reduce turbulences generated by the rotation and achieving a virtual zero vibration point.

The platter is 23mm thick in black Polyvinyl, a very elastic but deaf material, it features an extraordinary ability to reduce vibrations while the high-mass helps the rotational stability.

The platter is designed to operate at only 3mm from the plinth. Such small platter/plinth interference minimise turbulences for the greatest noiseless functionality.

The choice of materials shows a dedication to the native ground that goes beyond the musical dimension of the product to create a truly unique experience.

**Every Gold Note product is 100% proudly designed, manufactured and assembled in Italy**

# KEY FEATURES

## CONSTRUCTION FEATURES

This section describes the special features of the Pianosa turntable, the construction details, the reasons for the technical choices and the originality of the design.

- The Pianosa is a rigid turntable that uses a 50mm thick plinth made of Hardwood or MDF interfaced with a 3mm stainless steel and a 20mm Black Lacquered MDF plinth.
- The plinth bears three adjustable aluminium feet to ensure high insensitivity to vibrations.
- The turntable platter is made of 23mm thick Polyvinyl, a particularly deaf polymer.
- The recessed Spindle allows the platter to spin very close to the turntable plinth in order to reduce the turbulence caused by rotation.
- The spindle is a high quality machined stainless steel piece that clamps the platter with its conical shape named Split-Spindle™, it's 60mm long to ensure a top class performance. A large longitudinal groove is located on its axis to allow the lubricating oil to run constantly. The longer spindle eradicates any pendulum effect and distributes the inertial energy along its entire axis, completely annulling any type of lateral friction.
- The bronze bearing is rectified to guarantee a smooth spindle rotational stability while a customised bottom platter bearing enables very low noise.
- The platter bearing is threaded outside in order to be tightly blocked to the plinth of the turntable on its own axis allowing a precise coupling.
- The custom AC 12 Volt micro-controlled motor allows 33⅓rpm & 45rpm electronic speed control and pitch adjustment. Besides the special motor guarantees a perfect rotation stability and great torque in complete silence.

# TECHNICAL SPECIFICATIONS

## **MAIN FEATURES**

Wow & flutter: 0,1%

Rumble: -77dB

Speed: 33 $\frac{1}{3}$ rpm and 45rpm  $\pm$ 0,1%

Speed Changing: electronic with fine pitch control

Transmission: 70 shores rectified black NBR belt

Motor: 12 Volt High Torque synchronous

Platter: 23mm Dampened Poly-Vinyl

Platter Spindle: Split-Spindle™ clamping design

Platter Bearing: Chromed Steel 5mm ball bearing

Tonearm: Gold Note B-5.1 (or opt. B-7 Ceramic)

Dust cover: transparent acrylic with hinges

## **POWER**

Power supply: 18V output

Power consumption: max 20W

100-240V, 50/60Hz

## **DIMENSIONS AND WEIGHT**

Dimensions: 425 W x 200 H x 360 D mm

Weight: Kg. 13.5 net - Kg. 18 boxed

## **FINISHES**

Lower Plinth: Italian Walnut or Black Lacquered MDF

Upper Plinth: Black Lacquered MDF

Metal parts: Black anodized aluminium (opt. Silver)

Platter: Black

# SET-UP INSTRUCTIONS

## FIRST OPERATION

1. Please remove carefully all the protecting foam and check if all the listed items are supplied.
2. Place the Pianosa deck on a levelled surface, such as a wall shelf immune to footfall, then level the turntable.
3. Plug the DIN/RCA cable of the arm on the shaft female connector DIN side, hooking the RCA connectors to the amplifier phono input.
4. Install the counterweight into the rear arm wand of the arm selecting the correct cartridge tracking weight with the help of a precision scale (not supplied).
5. Install the turntable belt surrounding the hourglass motor pulley and the platter outer perimeter.
6. Plug the Power Adapter cable to the 12V rounded plug Turntable Speed Control and then plug the AC adapter to the AC plug once selected the right international plug supplied.

## POSITIONING THE PIANOSA

Your PIANOSA turntable has been designed for Hi-Fi systems. It must be protected from direct sun and humidity.

Do not place it near heating sources, electrical and electronic motors, mobile phones etc.

The levelling and positioning on a solid shelf, as explained in the previous chapter, is fundamental to ensure the best audio performances.

## OPERATING THE 33 $\frac{1}{3}$ rpm & 45rpm CONTROL

The turntable is fully controlled by an electronic power supply.

## TURNTABLE SPEED CONTROL ADJUSTMENTS

- Inner button starts and stops the 33 $\frac{1}{3}$ rpm speed. Once the 33 $\frac{1}{3}$ rpm is playing its red LED light turns on.
- Outer button starts and stops the 45rpm speed. Once the 45rpm is playing its red LED light will be on.

The Pianosa also features a fine speed adjustment "Pitch Control" function to allow a very fine and precise speed calibration.

## PITCH CONTROL MODE

To enter the PITCH CONTROL MODE press and hold for 4 seconds both 33 $\frac{1}{3}$ rpm and 45rpm buttons while the turntable is spinning.

When the red LED light shuts down, the unit is ready for the fine speed adjustment.

- PITCH –  
press repeatedly the 33 $\frac{1}{3}$ rpm button until the correct speed is reached.

The LED light flashes every time the button is pressed.

- PITCH +  
press repeatedly the 45rpm button until the correct speed is reached.

The LED light flashes every time the button is pressed.

**See pag.14 for images.**

To switch off of the PITCH CONTROL MODE press and hold for 4 seconds both the 33 $\frac{1}{3}$ rpm and the 45rpm buttons until the LED light is on and steady again.



# INSTALLING THE PLATTER

## CONTENT OF THE TURNTABLE BOX

- 1 Platter
- 2 Oil Vessel
- 3 Ball bearing
- 4 Platter Spindle Tip + Platter spindle

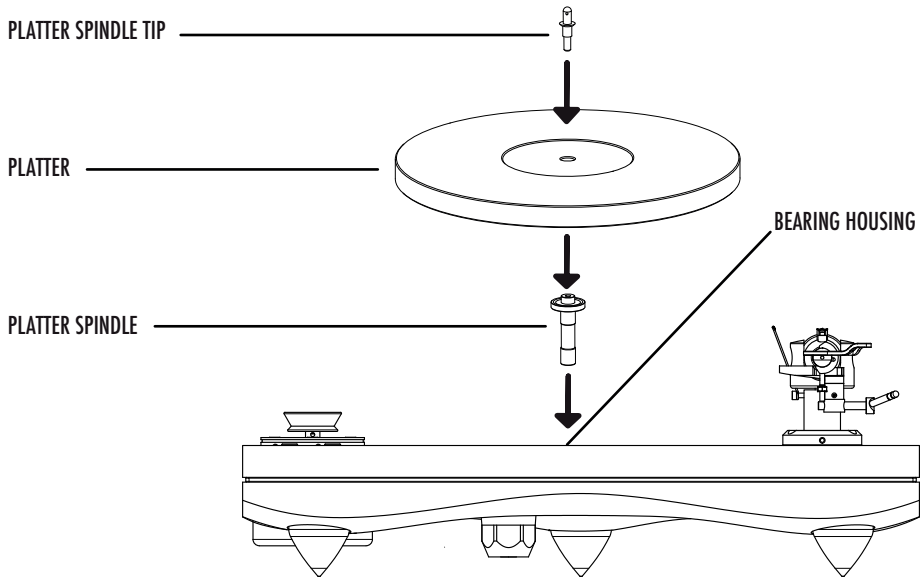
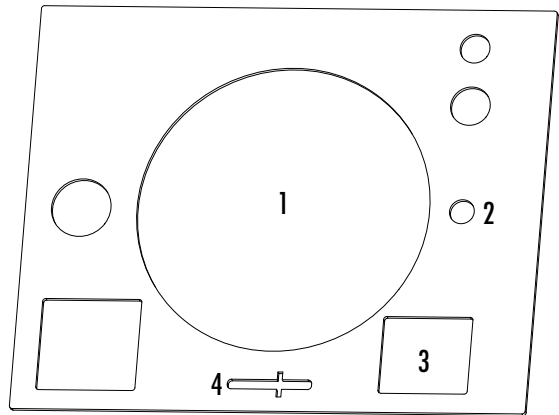

# INSTALLING THE PLATTER

## INSTRUCTIONS

- 1 Remove plug from the middle of the turntable
- 2 Insert the Ball Bearing into the Bearing Housing\* of the turntable taking care to center it on the bottom seat
- 3 Oil the Platter Spindle as shown in figure 3
- 4 Insert the Platter Spindle into the Bearing Housing
- 5 Lay the Platter on the Platter Spindle
- 6 Secure the Platter Spindle Tip in the threaded hole of the Platter Spindle

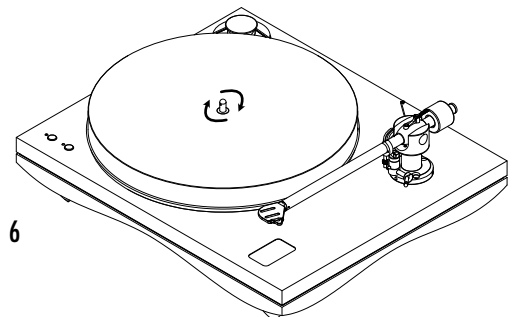
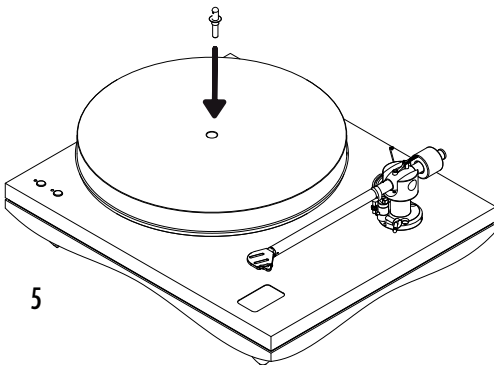
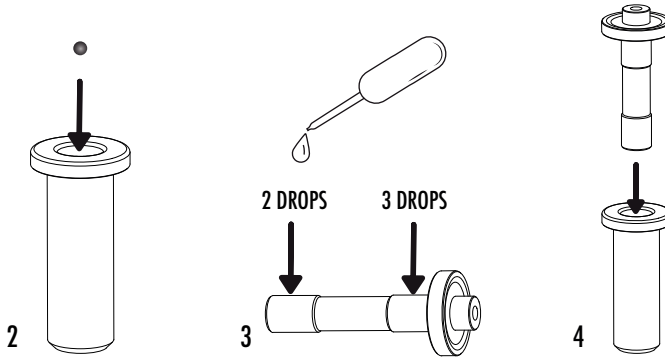
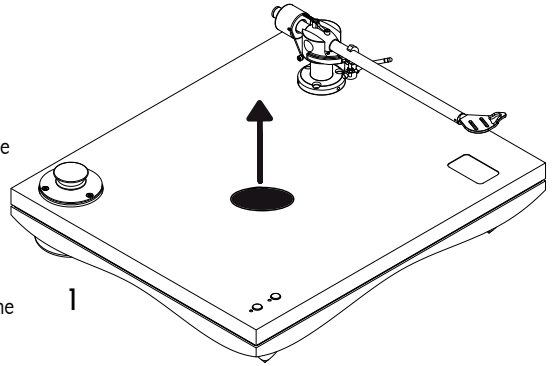

**\*PLEASE NOTE:** the Bearing Housing is already installed in the plinth of the turntable. Do not remove it.

## INSTALLING THE BELT AND THE TONEARM CABLE

Wrap the belt around the pulley and the platter as shown in the picture:

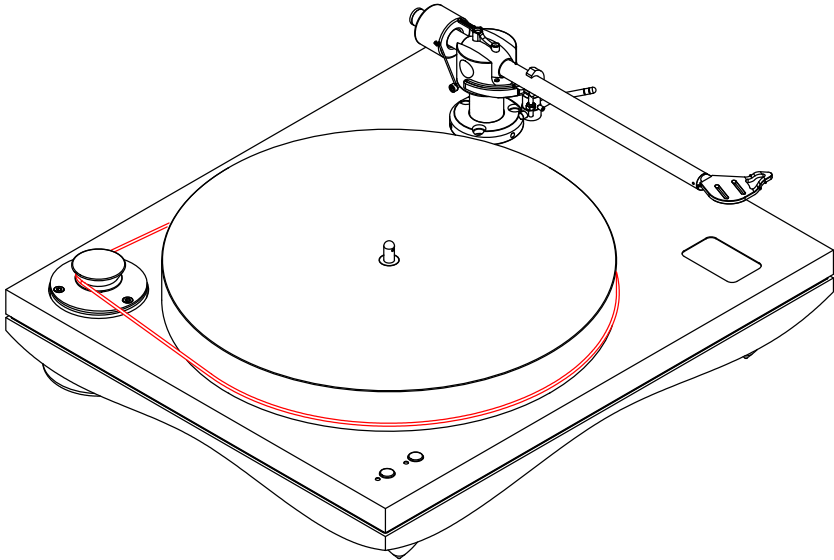

The tonearm cable should be always connected before the tone arm is installed on the turntable.

Always pay attention to the cable and make sure it is connected before placing the tonearm in position.

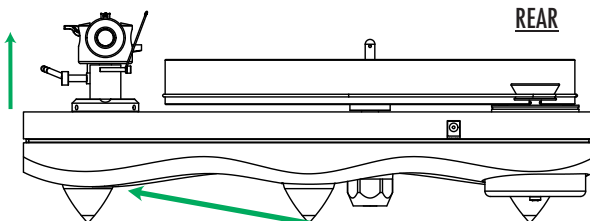

The Male DIN plug and the female DIN plug must be connected as shown in the picture below.

# ANTI-SKATING, AZIMUTH, COUNTERWEIGHT ADJUSTMENTS

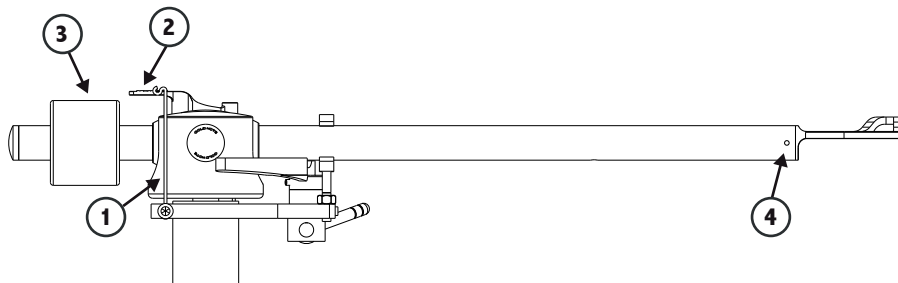

1. ANTI-SKATING nylon wire with bullet counterweight
2. ANTI-SKATING adjustment bar
3. TONEARM COUNTERWEIGHT: to set up the correct tracking force depending on the phono cartridge in use
5. SHELL AZIMUTH ADJUSTMENT: to adjust the alignment of the tonearm head-shell (0,9mm Allen Wrench)

## INSTALLING THE ANTI-SKATING SYSTEM

1. Slip the loop of the ANTI-SKATING nylon wire over the groove of the ADJUSTMENT BAR
2. Feed the wire through the loop of the SUPPORT HOOP
3. Adjust the ANTI-SKATING force choosing the correct groove on the ADJUSTMENT BAR

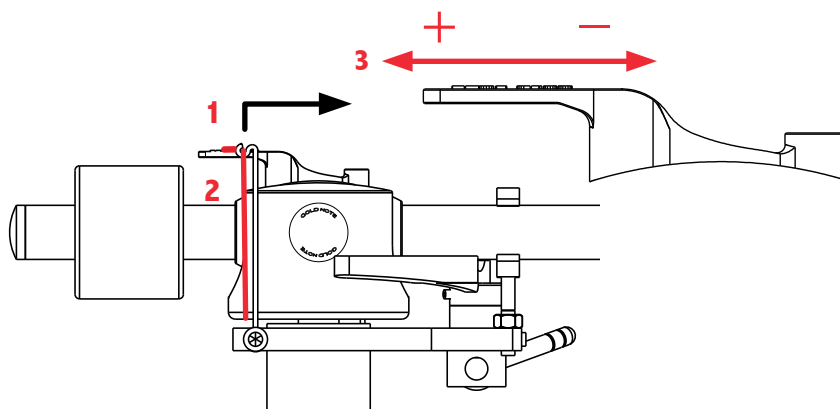

# VTA SETUP

## VTA SETUP

Loose the **Hex-bolt indicated by the arrow** on the collar using the 1,5mm Allen Wrench supplied to lift **up or down the arm** correctly adjusting the VTA as necessary.

Allen key 1,5 mm

Arm board

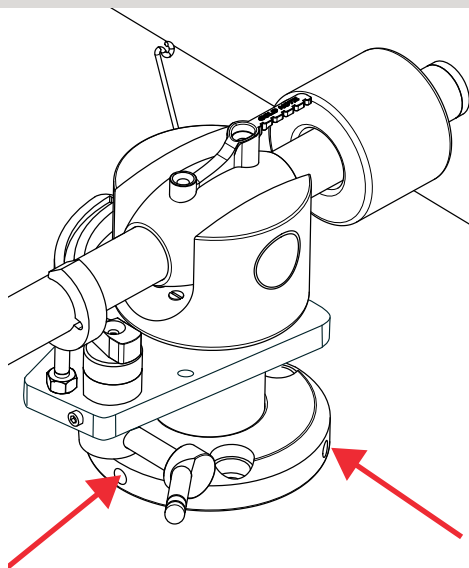
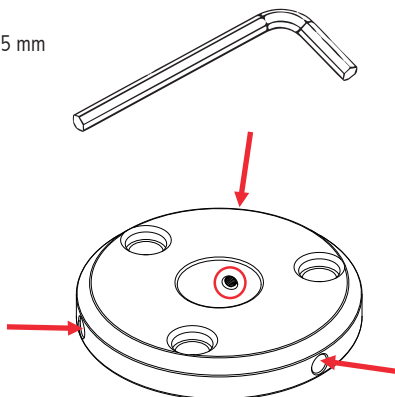

## AZIMUTH

After the cartridge has been properly installed on the tone arm, adjust the Azimuth of the shell with the supplied 0,9mm Allen Wrench.

Setting a correct Azimuth will provide a better audio performance.

Allen key 0,9 mm

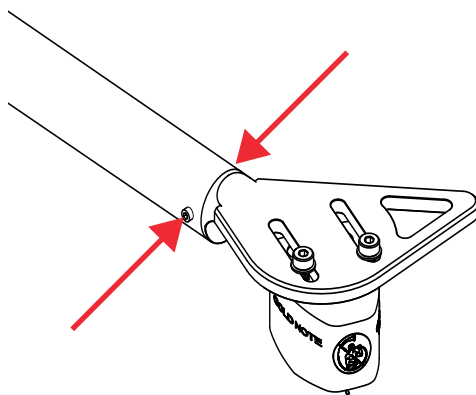
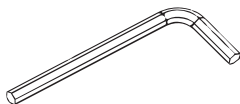

# POWER SUPPLY

## POWER SUPPLY ADAPTER

Is necessary to use the correct AC plug based on your local area.

Size: 67.3 x 43.5 x 37.5 mm

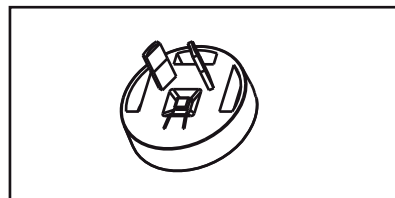
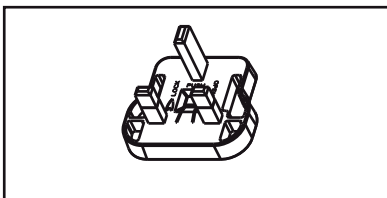
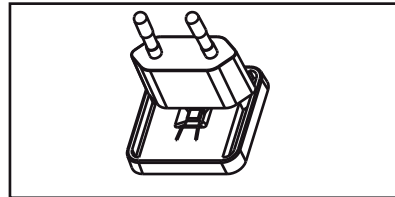
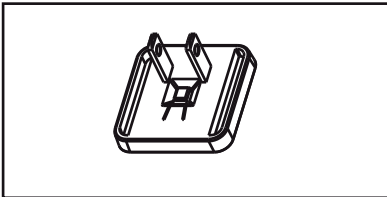
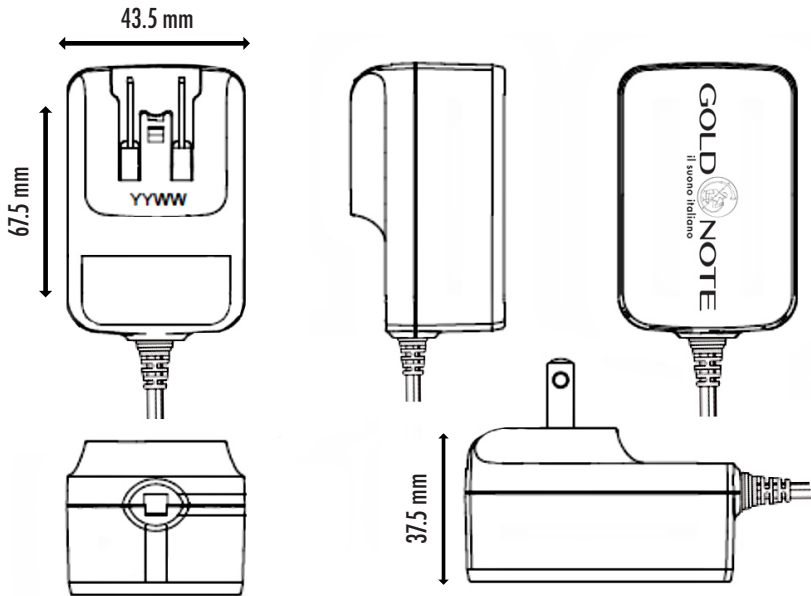

**PLEASE NOTE:** Before plugging the AC adapter plug the round connector indicated here.

# POWER ADAPTER AND SPEED CONTROL

## CONNECTING THE POWER SUPPLY ADAPTER

Use only the original GOLD NOTE AC adapter to power the turntable to ensure the correct functioning.

**PLEASE NOTE:** Before plugging the adapter in to the AC make sure the connector is plugged into the turntable.

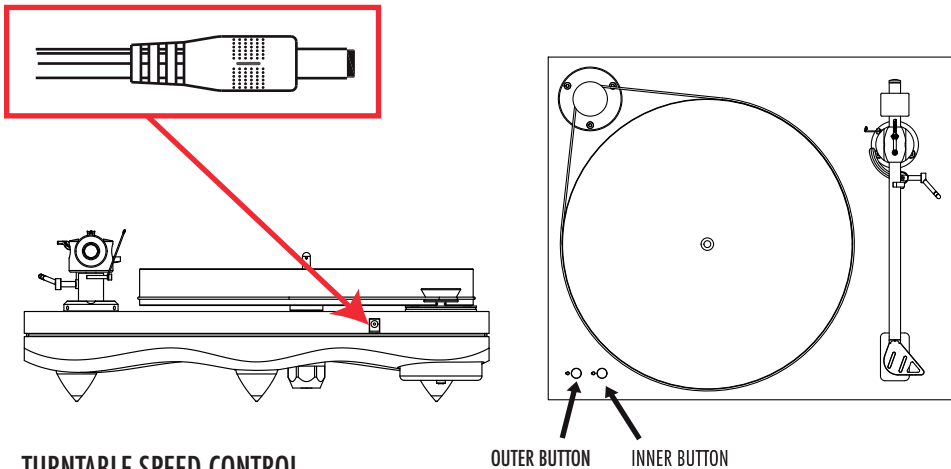

## TURNTABLE SPEED CONTROL

- INNER BUTTON starts and stops the 33 $\frac{1}{3}$ rpm speed. When the 33 $\frac{1}{3}$ rpm is playing its red LED light turns on.
- OUTER BUTTON starts and stops the 45rpm speed. When the 45rpm is playing its red LED light turns on.

The Pianosa also features a fine speed adjustment “Pitch Control” function to achieve a precise control over the speed of the turntable.

## PITCH CONTROL MODE

To enter the PITCH CONTROL MODE press and hold for 4 seconds both the 33 $\frac{1}{3}$ rpm and the 45rpm buttons while the turntable is spinning at 33 $\frac{1}{3}$ rpm or 45rpm until the red LED light shuts down. The unit is now ready to adjust the speed with the help of the stroboscope.

- PITCH – press in sequence the 33 $\frac{1}{3}$ rpm button until the correct speed is reached.

The LED light flashes every time the button is pressed.

- PITCH + press in sequence the 45rpm button until the correct speed is reached.

The LED light flashes every time the button is pressed.

To switch off of the PITCH CONTROL MODE press and hold for 4 seconds both the 33 $\frac{1}{3}$ rpm and the 45rpm buttons until the LED light is on and steady again.

# CALIBRATION: CARTRIDGE OVERHANG, ALIGNMENT AND SPEED

Our turntables and tone arms are always supplied with the Gold Note Calibration Tool to calibrate correctly the setup. With this tool you will be able to adjust:

- A) Phono Cartridge alignment
- B) Overhang
- C) 45rpm and 33 1/3rpm speed (requires a strobe light)

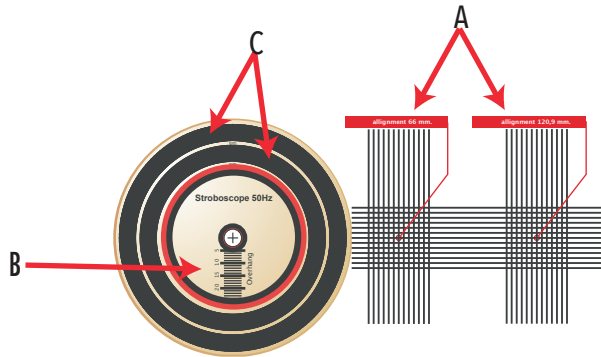

## SPEED ADJUSTMENTS

Check the speed with the help of a strobe light (eventually a home NEON can also work).

When the speed is correct you will be able to see the sequence of black rectangular signs as if they were stable and fixed while the platter is spinning.

The outer line is to check the 33 1/3 rpm

The inner line is to check the 45rpm

## OVERHANG

To set the correct overhang the Calibration Tool must be inserted on to the turntable record pin and the cartridge Tip must be positioned on top of the pin.

Adjust the position of the cartridge until the suggested overhang of the phono cartridge is reached as indicated by the manufacturer.

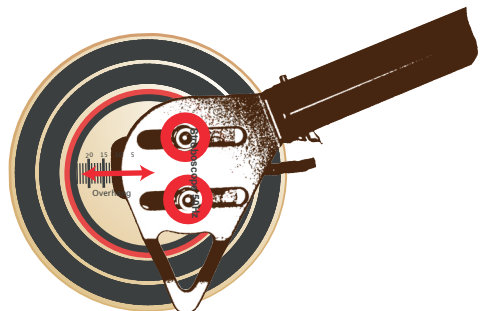
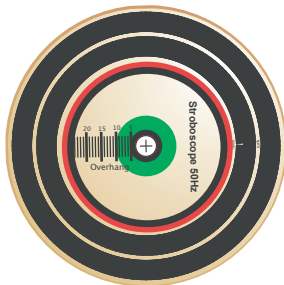



# CARTRIDGE ALIGNMENT

## PHONO CARTRIDGE ALIGNMENT

To correctly align the phono cartridge and achieve the best tracking position, point the tip of the phono cartridge into the white circles as in the picture below.

The body of the phono cartridge must be aligned to the vertical stripes in order to achieve the best position for musical reproduction.

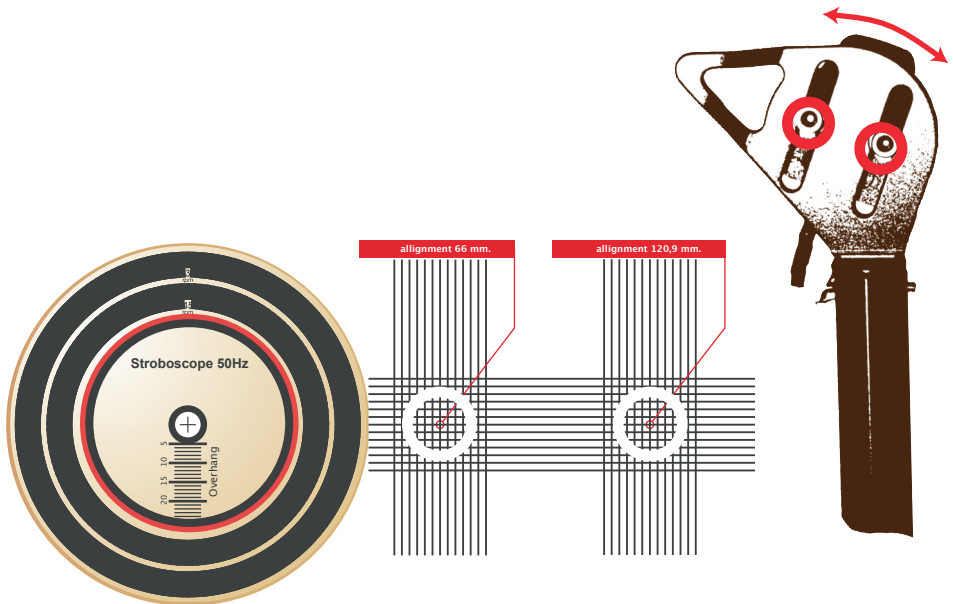

## DETACHABLE DUST COVER

The new Gold Note dust cover features detachable hinges, a new proprietary design developed to let you enjoy your turntable at the best in any situation.

The new dust cover is incredibly versatile and allows the usage of the turntable with or without it.

We are proud to offer this new solution to our clients to help them preserve their turntables in ideal functional and cosmetic conditions.

PICTURE 1

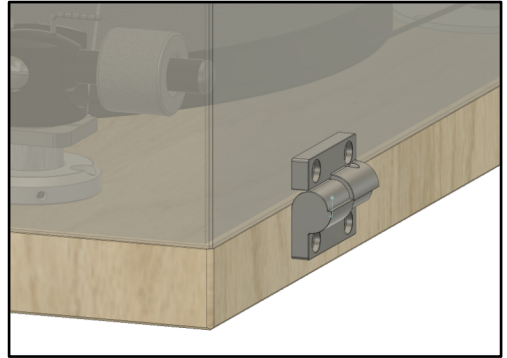

The new design also provides a stop point at about 90° to the dust cover: in this position it automatically stops and the hinges will hold the dust cover avoiding overturning.

PICTURE 2

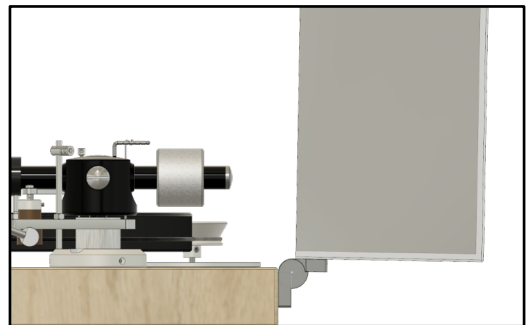

Removing the dust cover is simple and quick:

lift the dust cover until it reaches the 90° stop point and it's completely opened, then gently slide it towards LEFT (facing the turntable) to detach it from the plinth.

Please Note: the dust cover can be removed and reinserted only when it's in its resting position, completely opened at 90°.

PICTURE 3

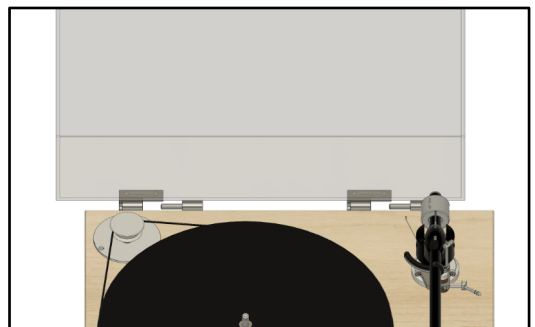

# WARRANTY AND SERVICE

## **WARRANTY**

To validate the warranty is necessary to register the unit on the Gold Note internet web site within 15 days from the purchase on the appropriate area of the web site:

[www.goldnote.it/warranty](http://www.goldnote.it/warranty)

If the unit is not registered correctly or has been purchased from a different country of the purchaser home address the unit will not be covered by any warranty and the registration will be refused.

The warranty does not cover in any case: Tubes, Phono Cartridge Styli and Batteries.

## **SERVICE**

Every GOLD NOTE® product is the result of meticulous technological research, and consequently their correct functioning is guaranteed. In spite of this it is possible that problems may emerge which non-specialist users cannot resolve.

In this case, contact your dealer to be advised on how the fault can be solved.

Do not return any object directly to the factory or to the national distributor or without being authorised to do so.

In such cases both GOLD NOTE® and the distribution agents operating within your territory decline responsibility of any kind.

For more information please visit [www.goldnote.it/service](http://www.goldnote.it/service)

## **PLEASE NOTE**

Descriptions and technical characteristics may vary at any time and without notice.

## TROUBLESHOOTING

PROBLEM	CAUSE	SOLUTION
Levelling the turntable	The turntable is not levelled	With a spirit level, only level the Turntable Platter through its shelf layer eventually screwing its feet just for very fine adjustment, take care of levelling the platter on its vertical and horizontal lines.  Be sure that the turntable layer is enough solid and rigid to support the weight of the turntable Easily.
Cleaning the turntable	The turntable is dirty and requires cleaning	With EXTREME care use ONLY very soft 100% cotton cloth to sweep dust and stains out. Any acid or not extremely soft cloth will irreversibly damage the turntable fine aesthetic. Do not use any alcohol to clean the turntable anodised label, pulley and motor spindle. Only dry cloth is allowed.
Motor heating	The motor is too hot	AC synchronous motors as the ones used by Gold Note may warm up to 50° Celsius without creating any problem.
Noise on startup	The turntable produces a slight rubbing noise upon startup	It is normal for the belt to produce a slight noise when starting.

For spare parts visit the official Gold Note store at:

[www.akamaiaudio.it](http://www.akamaiaudio.it)

# IMPORTANT SAFETY INFORMATION



**CAUTION**  
RISK OF ELECTRIC SHOCK  
DO NOT OPEN



## **CAUTION!**

TO REDUCE THE RISK OF ELECTRIC SHOCK, DO NOT REMOVE COVER (OR BACK). NO USER-SERVICEABLE PARTS INSIDE. REFER ONLY TO QUALIFIED GOLD NOTE SERVICE PERSONNEL FOR SERVICE



**WARNING**  
FIRE OR SHOCK HAZARD



## **WARNING!**

TO PREVENT FIRE OR SHOCK HAZARD, DO NOT EXPOSE THIS APPLIANCE TO RAIN OR MOISTURE

Do not disassemble any part of the product.

Do not use any part of the product for other purposes.

For service and problems of any kind, contact qualified Gold Note personnel.

Protect the product from rain and humidity and keep away from heat sources, electric and electronic motors etc.

The power Chord supplied must be used only on this unit.

Gold Note does not have responsibility for any improper use of this unit.

This appliance has a serial number located on the rear panel.

Please record the model and serial number and retain them for your records.

Serial Number: \_\_\_\_\_

Model: \_\_\_\_\_

# IMPORTANT SAFETY INFORMATION

- 1.** Follow the instructions and store them
- 2.** Heed all warnings
- 3.** Do not use this apparatus near water
- 4.** Clean only with a dry cloth
- 5.** Do not install near heat sources such as radiators, heat registers, stoves or other apparatus
- 6.** Do not defeat the safety purpose of the polarised or grounding-type plug: a polarised plug has two blades with one wider than the other.

A grounding type plug has two blades and a third grounding prong.

The wide blade or the third prong are provided for your safety.

If the provided plug does not fit into your outlet, consult an electrician for replacement of the obsolete outlet.

- 7.** Protect the power cord from being walked on or pinched particularly at plugs, convenience receptacles, and the point where they exit from the apparatus.
- 8.** Only use attachments/accessories specified by the manufacturer.
- 9.** Use only with the cart, stand, tripod, bracket, or table specified by the manufacturer, or sold with the apparatus.

When a cart is used, use caution when moving the cart/apparatus combination to avoid injury from tip-over.

- 10.** Unplug this apparatus during lightning storms or when unused for long periods of time.

- 11.** Refer all servicing to qualified service personnel only.

Servicing is required when the apparatus has been damaged in any way (such as when the power cord or plug is damaged, liquid has been spilled or objects have fallen into the apparatus, the apparatus has been exposed to rain or moisture) and in any case when the apparatus does not operate normally or has been dropped.





 [goldnote\\_italy](https://www.instagram.com/goldnote_italy)

 [Gold Note Audio](https://www.facebook.com/GoldNoteAudio)

 [Gold Note](https://www.youtube.com/GoldNote)

Akamai S.r.l.  
[service@goldnote.it](mailto:service@goldnote.it)  
[www.goldnote.it](http://www.goldnote.it)