



NDS6831A

User Manual



DIGITAL SOUND PROCESSOR

Contents

Notice 1

Troubleshooting 1

Packing List 1

1. Introduction 2

2. Software Introduction 4

3. Product Technology Data 9

Notice

1. To prevent short circuit, please keep the device away from water or wet places.
2. If water or any other liquid soak into the device, cut off the power immediately, and call our service engineer of inspection, in case of emergency.
3. Users are not allowed to dismount the device, please contact our service engineers when it's necessary.

Troubleshooting

Check all the cables and ports all perfectly safe before you switch on the power. Common troubleshooting procedure:



Troubleshooting method:

No.	Malfunction	Reason and Solution
1	No Power	<ul style="list-style-type: none">• Check the power connection.• Check the ACC connection.
2	No Sound	<ul style="list-style-type: none">• Is it in mute mode.• Have you choose the right input signal channel.
3	Unable to connect USB	<ul style="list-style-type: none">• Check the USB connection.• Check if the driver "HID-compliant device" has been installed in your PC.

Whats' in the Box

NDS6831A	1Pc
User Manual	2pcs(1 Chinese, 1 English)
USB2.0 Cable(1.5m)	1Pc
High-level Input Line (150mm)	1Pc
Self-Tapping Oval Head Screws (4x20mm)	4Pcs
Cross Head Mechanical Screws (3*6mm)	8Pcs
Installation Bracket	4Pcs
Velcro	2Prs
Allen Wrench(2.5*50.5mm)	1Pc
Allen Wrench(1.5*18.8mm)	1Pc

Introduction

The interface diagram is as follows :

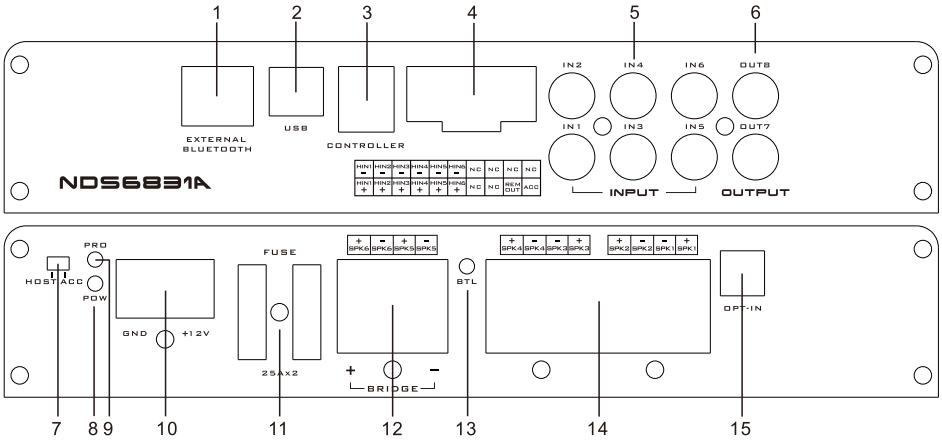

1.External Digital Bluetooth Input

Connect the external Bluetooth, the LED indicator will flash, the indicator will stop flash and will be always on once you have connected your Mobile phone to the device, then you can play music in your phone, and the device will change the high level input to Bluetooth Input.

Notes: Android Phone, APP function only can be used when on Bluetooth Mode.

2.USB Port, Connect to the computer tuning software

No need to download the driver installation, connected to the computer sound software installed automatically.

3.The controller port

Data call and total volume adjustment can be performed by the line controller.

4.High level input port

HIN1	HIN2	HIN3	HIN4	HIN5	HIN6	NC	NC	NC	NC
-	-	-	-	-	-	NC	NC	NC	NC
HIN1	HIN2	HIN3	HIN4	HIN5	HIN6	NC	NC	REM OUT	ACC
+	+	+	+	+	+	NC	NC	REM OUT	ACC

a. "+" is positive or positive; "-" is negative or inverted (ground).

b. Only the special wire for the original car is selected, or the user can define the external wiring material by himself.

c. Before connecting the power supply, you must confirm that the power supply meets the designed power requirements and connect in strict accordance with the equipment instructions. Otherwise, the equipment may be damaged and may cause accidents such as fire, electric shock, etc.

5.Low level input port

Low Level Output, connect up to 6 channels speaker input.

6.Low Level output port

Low Level RCA Output, connect up to 8channels speaker output.

7.Machine start mode switch

When the switch is turned to the "ACC" terminal, the machine is started by ACC, and when it is turned to the "HOST" terminal, the machine is started by the high level input signal.

Introduction

8. Power indicator light

9. Protection light

10. Power port

11. 25A fuse

Two 25A fuses.

12. Power output port

5, 6 power amplifier output, can be bridged.

+	-	+	-
SPK6	SPK6	SPK5	SPK5

13. Bridge indicator

14. Power output port

1 ~ 4 way power output.

+	-	-	+	+	-	-	+
SPK4	SPK4	SPK3	SPK3	SPK2	SPK2	SPK1	SPK1

15. Fiber port input

Connect the car CD or DVD fiber optic cable, switch the machine audio source to digital input, and play the optical digital signal.

Software Introduction

PC Software Operation Introduction

(PC can be downloaded from the official website (<http://www.nakamichicaudio.com>, CONTACT, Downloads))

Computer Configuration Requirements: Screen resolution higher than 1280 x 768, otherwise the software UI is incomplete, only suitable for windows operation system laptop, desktop and pads.



1.Menu editing area



Main functions: File, options operation.

- Click the "File" pop-up window, and select to load the scene on you computer, save it as a scene on you computer, load the whole machine scene or save the whole machine scene.
- Click on "Options" to select Chinese and English switching, advanced (noise gate), firmware update, factory reset, help and about settings.

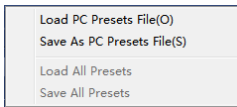

2.Function edit area



Main functions: scene, master source, channel type, link, mixer and mode setting.

- Scene: 6 sets of scene data can be recalled or stored.
- Master source: Click the input audio source drop-down list to select the input audio source. There are Optical, Phone, AUX and Hi.Level.



Software Introduction

- c.Reset: Click Reset to clear the channel type or restore the default channel type.
- d.Link: Click the Link to set the Link synchronization mode: copy from left to right or copy from right to left.
- e.Click "Mixer" to enter the mixing interface, the interface is as shown below.

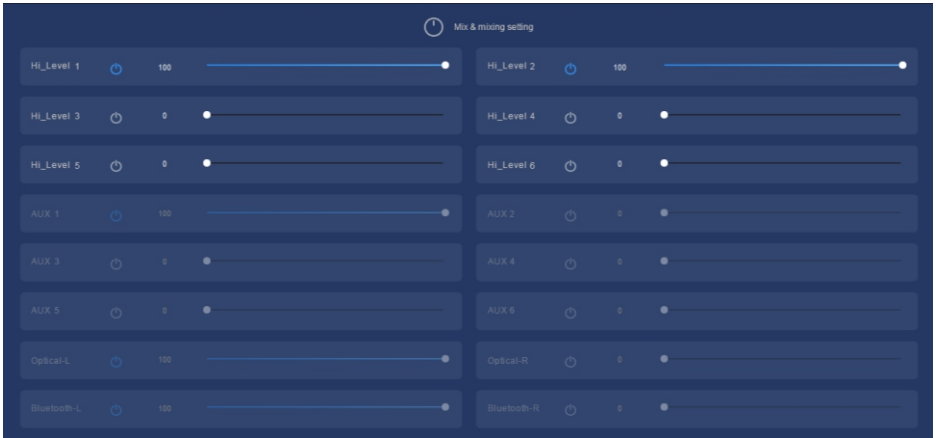

- f.Click on the Stereo mode to switch to the bridging mode.

3.Main volume and software connection editing area



Main functions: master volume and computer software connection settings.

- a.Main volume adjustment range: off, -59dB ~ 6dB. Click the speaker button to mute the main volume.
- b.Click the "Not Connected" button to connect the host with a PC.



4.Function editing area



Main function: configure the type of output channel.

5.Channel delay, volume, phase editing area



Software Introduction

- a. Push the fader left or right to adjust the sound size, or enter a value or roll the mouse wheel in the volume input box to adjust the sound size. Click the speaker button to switch mute.
- b. Positive phase adjustment: Click [0°] or [180°] to switch between positive phase and reverse phase.
- c. Delay: set the delay value by scrolling the mouse wheel in the delay input box, or enter the value to set the delay value.
- d. Delay Unit button: Click the drop-down list to select milliseconds, centimeters, and inches.

6. Channel divider editing area

Main Function Setup: Channel High & Low Pass Filter Setup
 Adjustable: Filter Type, Frequency point and Q Value (Gradient or Slope).
 When the slope is 6dB/Oct, the type is NULL.



7. Equalizer editing area

- a. Reset EQ: It is used to restore the parameters of the 31-band equalizer to the original pass-through mode (the frequency of the equalizer, the Q value and the gain are restored to the initial value).
- b. Restore EQ: Switch between the currently designed equalizer state parameters and the pass-through mode (the gain of all equalization points is restored to 0 dB, the frequency and value are unchanged).
- c. Click PEQ Mode to switch GEQ Mode. The Q value and frequency cannot be adjusted in the PEQ Mode interface.



8. Channel EQ area

Main function configuration: Equilibrium design of current output channel, 31-band equalization adjustable: frequency, Q value (response bandwidth) and gain (increasing or decreasing the frequency response amplitude near the frequency point).

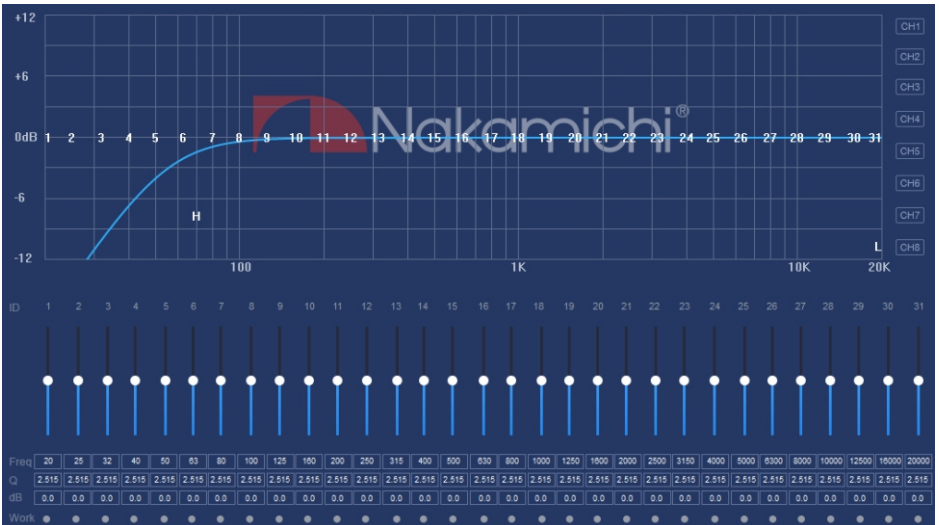

Software Introduction

Smart-phone Software Operation Instruction

(PC can be downloaded from the official website (<http://www.nakamichicaraudio.com>, CONTACT, Downloads))



Home



Delay

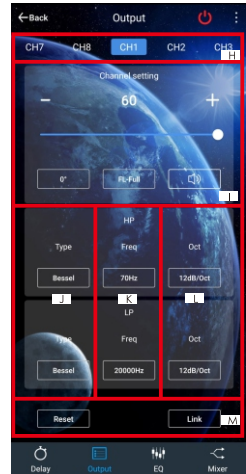

Output

1. Home interface

It can restore factory settings, share sound effects, save sound effects, turn on local sound effects, check the model and version number of the unit, and exit the software operation; volume, sound source, mode settings; storage and recall of 6 sets of preset scenes.

A.Connection Status:

Red means not connected, green means connected.

B.Menu:

You can restore factory settings, share sound effects, save sound effects, turn on local sound effects, check the model and version number of this unit, and exit the software operation.

C.Volume adjustment:

Press and hold the volume scale clockwise or counterclockwise to adjust the volume. The main volume range is 0 ~ 66, The subwoofer range: 0 ~ 60, The medium, high and low volume range -12dB ~ + 12dB. Tap the speaker button to mute the master volume.
Sound source: There are optical fiber, Bluetooth, low level and high level to choose from.
Mode: switch between stereo mode and bridge mode.

D.Advanced settings:

Click [Advanced Settings] to enter the settings of the delay interface, channel interface, EQ interface and mixing interface.

E.Scene preset:

There are 1~6 presets to choose from.

2.Delay interface

Sound field positioning output delay adjustment.

F.Delay setting:

Click the speaker of the corresponding channel to enter the delay setting window of the corresponding channel, and slide the dots in the corresponding direction left and right to set the delay value. Delay settings can be made for CH1 to CH8 speakers. Delay range: millisecond range: 0.000 ~ 20.000; cm range: 0 ~ 692; inch range: 0 ~ 273.

G.Unit switching:

Switch between milliseconds, centimeters, and inches.

3.Channel interface

Channel high-low-pass crossover setting with high-low-pass independent filtering. Adjustable: Filter type, frequency and Q value (slope or slope).

H.Output channel selection:

Eight channels are available.

Smart-phone Software Operation Instruction

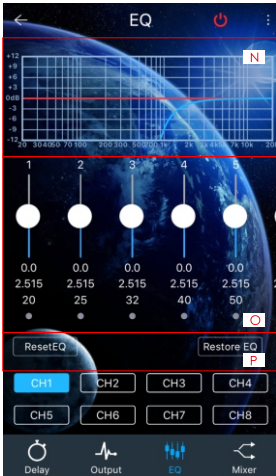

EQ

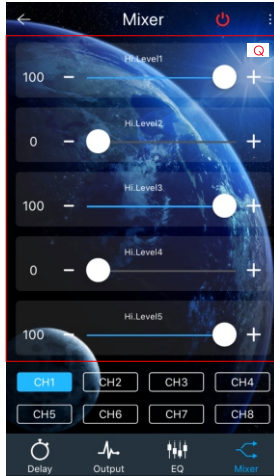

Mixer

I. Output channel volume setting:

You can adjust the volume by sliding left and right. The volume range is 0~60. Click the speaker button to mute.

J. Channel type:

Choose from Ning Ke Rui, Butterworth and Bessel.

K. Frequency Range: 20Hz~20KHz.

L. Slope selection:

6dB/Oct, 12dB/Oct, 18dB/Oct, 24dB/Oct, 30dB/Oct, 36dB/Oct, 42dB/Oct, 48dB/Oct and off can be selected.

M. Joint tuning and channel type settings:

Click the joint tuning button to bring up the joint tuning window and select the joint tuning method. Click Reset to reset the output channel type and make the output type customizable.

4. EQ interface

Corresponding to the adjustment of the output channel EQ curve (gain, Q value and frequency); reset equalization, pass-through equalization or parametric equalization operation settings.

N. EQ display:

Edit the display area.

O. Output EQ gain, Q value and frequency settings:

Output EQ gain setting: A total of 31 EQ, left and right sliding screen can select EQ, you can drag the slider up and down. Select the

first line value, and drag the slider bar left and right in the pop-up dialog box to adjust the adjustment range: -12dB~+12dB. Q value: Click the second line value, and drag the slider bar left and right in the pop-up dialog box to adjust, the adjustment range is 0.404~28.852. Frequency setting: Click the third line value, and drag the slider bar left and right in the pop-up dialog box to adjust it. The adjustment range is 20Hz~20KHz.

P. Reset equalization, restore equalization, pass-through equalization settings:

Click [Reset EQ] to restore the parameters of the 31-band equalizer to the original pass-through mode (the equalizer frequency, Q value and gain are restored to their initial values). When there is channel adjustment, display [straight-through equalization], click [straight-through equalization], click [OK], all values (frequency, Q value and gain) will return to the initial value. At this time, the [straight-through equalization] button will become [recovery equalization]. Press the button and click [Resume Equilibrium], all values (frequency, Q value and gain) will be restored to the value before the pass-through.

5. Mixing interface

6 high level, 6 AUX, digital left and digital right, Bluetooth left and blue right mixing selection and adjustment can be performed. The adjusting range is 0 ~ 100.

Product Technology Data

ProductData	
Dynamic Range(RCA Input)	≥100dB
S/N RCA(Input)	≥97dB
THD	≤0.05%
Frequency Response	20Hz ~ 20KHz
Input Impedance	High Level Input : 240Ω
Low Level Output Impedance	100Ω
Signal Input Range	RCA Input : 6.5Vpp; High Level Input : 28Vpp
Signal Output Range	RCA Output : 7.5Vpp; Amplifier: 4×50W+2×120W; Bridged: 300W
Working Temperature	-20 ~ 70℃
Power	DC 9V ~ 16V
REM Input	High Level Input Signal: HIN1+/HIN1- or ACC control cable
REM Output	+12V Start up Voltage Output
Standby Power	≤0.1W
Gross Weight	Approx. 1.98kg
Product Dimension	246(L) *160(W) *48(H)mm

Technical Sheet	
Input Type	6 Channels high level, 6 Channels Low Level,optical, external digital Bluetooth
Output Type	2 Channels low level, 1~4channels 50W power, 5~6channels 120W power
Output Gain	Gain Range: Mute, -59dB ~ 6dB
Output Signal EQ	Sound field 31-band equalizer engine 1. Frequency range: 20Hz ~ 20KHz, 1Hz Accuracy 2. Q value (slope): 0.404 ~ 28.85 3. Gain: -12.0dB ~ +12.0dB, 0.1dB Accuracy
Output Signal Crossover	Each output is equipped with multi-order high and low pass independent filters. 1. Professional filtering types: Link-Ril, Butter-W, Bessel 2. Filtering frequency division point: 20Hz ~ 20KHz. Resolution 1Hz 3. Filter slope (slope) setting: 6dB / Oct ~ 48dB / Oct and off
Output Phase and Time Alignment	Each output channel can be adjusted for phase and delay, parameter range: Phase: in-phase or reverse-phase (0° / 180°) Delay: 0.000 to 20.000 mill, 0 to 692 cm, 0 to 273 inch
Presets	Save 6 presets into the device

Product Dimension:

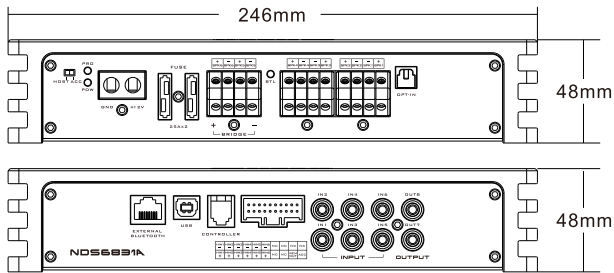
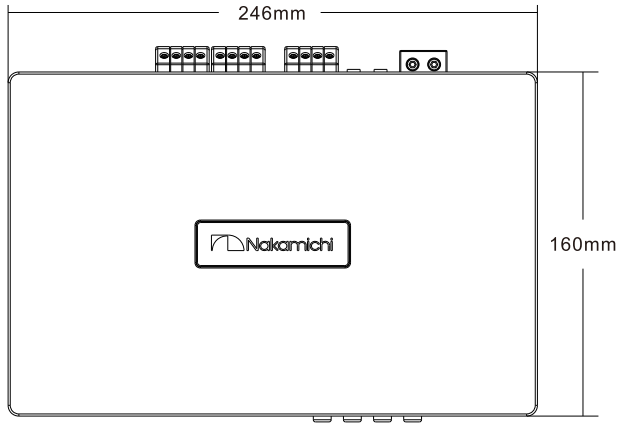

Installation Instruction:

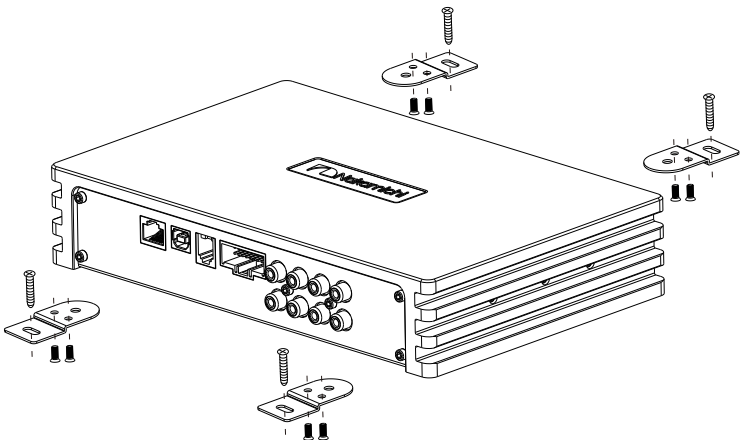

The speaker wiring in normal mode:

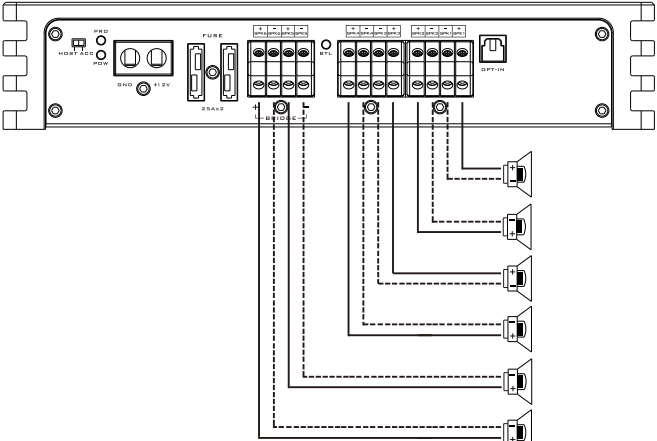

Speaker output
4Ω

The speaker wiring in bridge mode:

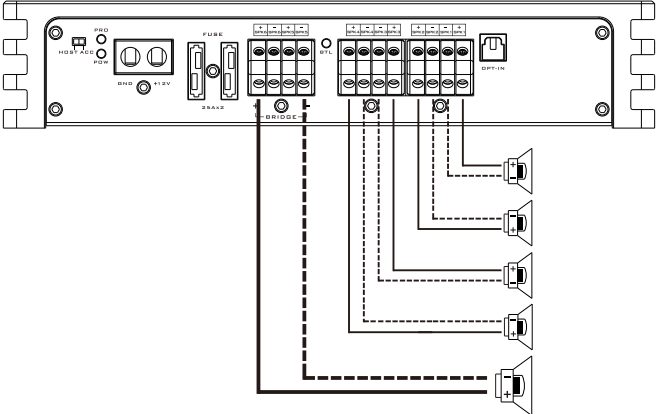

Speaker output
4Ω

CONTACT WITH US

 nakamichicaraudio.com

 [Nakamichi.Global](https://www.facebook.com/Nakamichi.Global)

 [nakamichi.caraudio](https://www.instagram.com/nakamichi.caraudio)

MADE IN CHINA